

FRY'S NEIGHBORHOOD CENTER

PAD B-SUITE 101

Anchored by Fry's Marketplace - the number one rural Fry's' and in the top five for the state - this retail center and its supporting retailers all enjoy high visibility and heavy consumer traffic thanks to its strategic location at the southwest corner of Glassford Hill and Florentine Roads.

Directly across from the bustling Town Center, this local shopping center taps into the needs of consumers for easy access, and ample and close parking. Its success is reflected in a low tenant turnover rate which makes this center a sought after location.



FOR MORE INFORMATION CONTACT

TERRY MARSHALL

terry@fainsignaturegroup.com
(602) 292-7119

RON FAIN

rfain@fainsignaturegroup.com
(928) 772-8844 ext. 105

FAIN SIGNATURE GROUP | 3001 N. Main Street #2B Prescott Valley, Arizona 86314



PAD B-SUITE 101

1,500 SQ. FT.

3140 N. Glassford Hill Road, Suite 101 Prescott Valley, AZ 86314



PAD B

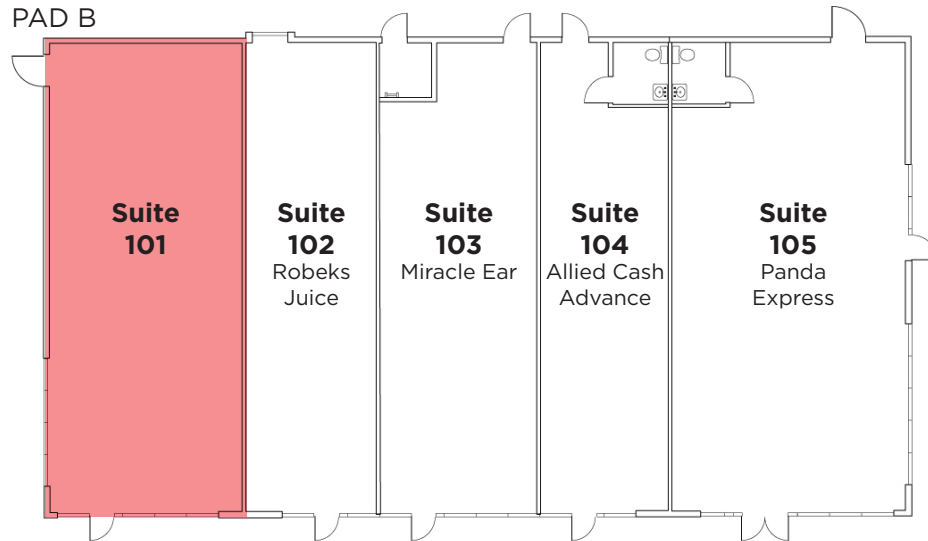

© 2021 FAIN SIGNATURE GROUP. All rights reserved. This information has been obtained from sources believed reliable, but has not been verified for accuracy or completeness. Any projections, opinions, or estimates are subject to uncertainty. The information may not represent the current or future performance of the property. You and your advisors should conduct a careful, independent investigation of the property and verify all information. Any reliance on this information is solely at your own risk. Fain Signature Group and the Fain Signature Group logo are service marks of Fain Signature Group, Inc. All other marks displayed on this document are the property of their respective owners. Photos herein are the property of their respective owners. Use of these images without the express written consent of the owner is prohibited.

DETAILS

Rent:
\$24 PSF +
NNN: \$6.66 (Estimated)

Total:
\$30.66 PSF

Total Annual Rent:
\$45,990.00

New paint and flooring through approved landlord allowance

5 - 10 Year Term

HVAC Contract Required

Tenant Improvements Negotiable

HIGHLIGHTS

Located in the economically robust Fry's Neighborhood Center-Prescott Valley Community.

Adjacent to Glassford Hill Road-the main artery connecting Hwy 69 and Hwy 89A.

Walking distance to Homestead-Prescott Valley's newest residential development.

High-traffic area includes the Findlay Toyota Center, Harkins Theatres, Walmart Superstore, Kohl's and the Town Center.

SUITE 101

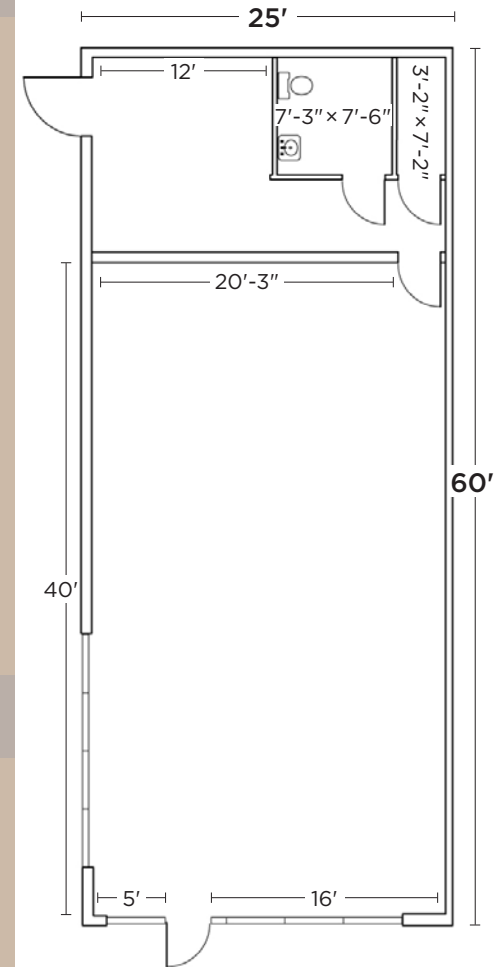

FAIN SIGNATURE GROUP
PROPERTIES, INC.

STATUS

Leasing and land opportunities are available

LOCATION

Southwest corner of Glassford Hill and Florentine Roads.

SHOPS A - 3010 N. Glassford Hill Road

SQ. FT.

For sale or build-to-suit

105,415

PAD B - 3140 N. Glassford Hill Road

SUITE

SQ. FT.

Available	101	1,500
Robeks Juice	102	1,000
Miracle Ear COMING SOON	103	961
Allied Cash Advance	104	980
Panda Express	105	2,000

PAD E - 3088 N. Glassford Hill Road

SUITE

SQ. FT.

Firehouse Subs	101	2,000
Casa Perez	102 & 103	3,500
Available	104	1,500

SHOPS B - 7025 E. Florentine Road

SUITE

SQ. FT.

Fantastic Sam's	101	1,167
Streets of New York	102	3,000
Lynn's Nail and Spa	103	1,384
Queen Esther's Closet	104	1,361
Edward Jones	105	1,083
The Boba Bliss	106	1,200
Available	107	1,200
Colt Cleaners (CMWCO, LLC)	108	1,600

FRY'S NEIGHBORHOOD CENTER

PRESCOTT VALLEY MARKET PROFILE

AVERAGE HOUSEHOLD INCOME

0-5 Minutes	\$56,345
5-10 Minutes	\$58,136
10-15 Minutes	\$67,206

NUMBER OF HOUSEHOLDS

0-5 Minutes	2,767
5-10 Minutes	9,025
10-15 Minutes	10,376

POPULATION

0-5 Minutes	7,441
5-10 Minutes	22,832
10-15 Minutes	25,587
Total Within 15 Minutes	55,860

AVERAGE AGE

0-5 Minutes	36
5-10 Minutes	41
10-15 Minutes	51

GLASSFORD HILL ROAD DAILY TRAFFIC COUNTS*

State Rte 89A to Long Look Drive	28,100
Long Look Drive to Florentine Road	33,700
Florentine Road to State Rte 69	28,100

*based on Prescott Valley data

